

Righetti
smart vacuum lifters

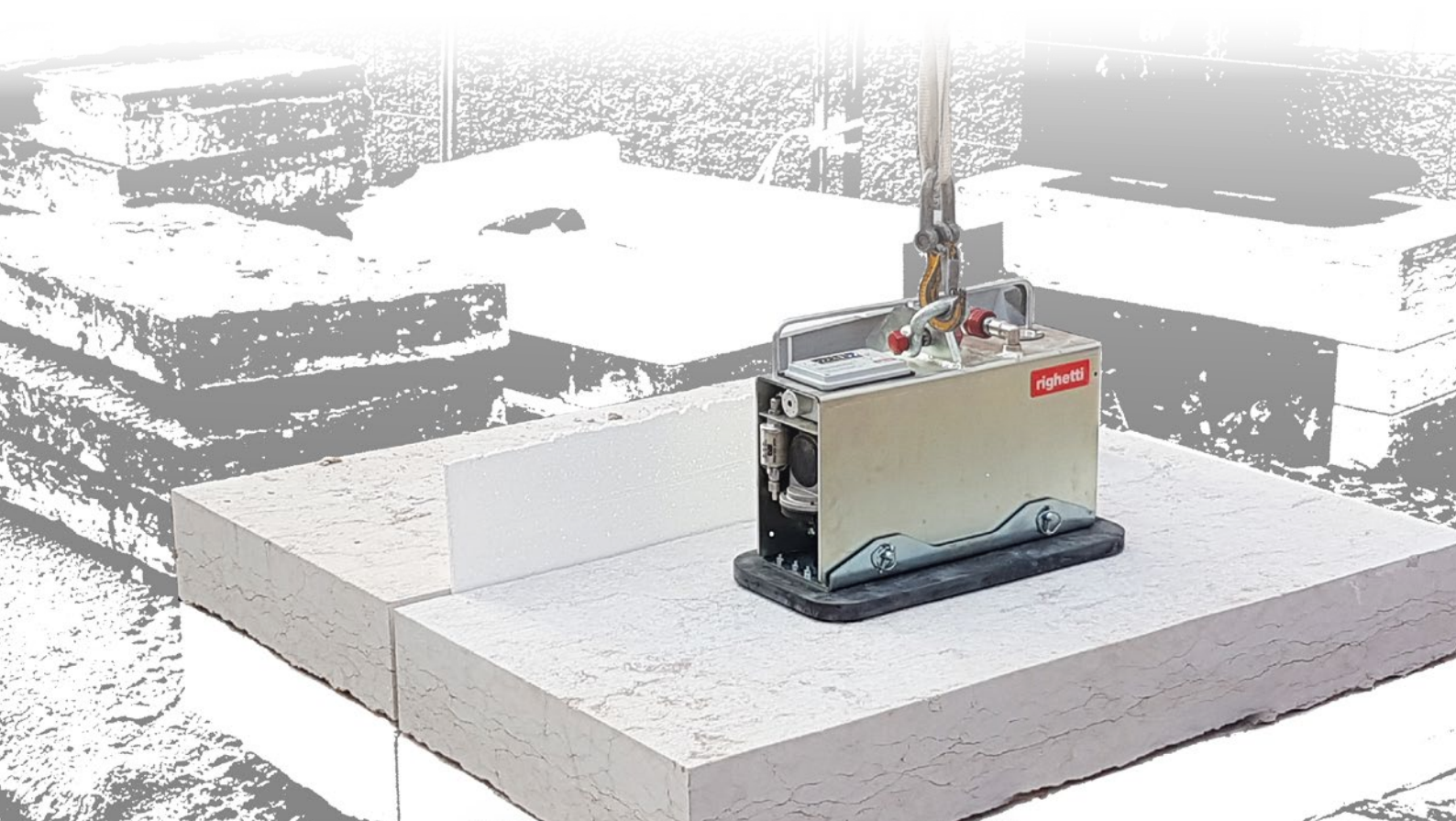

S1 Series

Stone vacuum lifters
for outdoor use

Vacuum
lifters
SPECIALISTS

righettivacuumlifters.com

S1 Series



Horizontal lift



Vertical lift



Manual tilt

Designed for outdoor use

3 reasons to choose S1

1

AUTONOMOUS OPERATING SYSTEM

Working on site with wires is a real struggle. That's why we developed two autonomous operating systems to let you work cordless and hassle-free.

2

COMPACT FOR CONSTRUCTION SITE

S1 series offers an unbeatable suction power in a compact and lightweight frame. The vacuum lifter is designed in every detail to optimize its functioning.

3

INTERCHANGEABLE PADS

Easily adapt the vacuum lifter to the load's size and weight by switching between different suction pads.

Cordless, versatile and lightweight vacuum lifters with interchangeable pads to adapt to different shapes.

S1 series is ideal for outdoor stone installations thanks to its autonomous power supply and its compact size. Depending on your lifting needs, we offer you two models: S1-MP and S1-B.

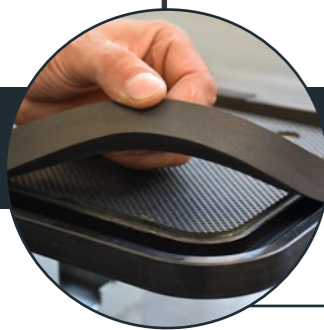

GASKETS EASY AND QUICK TO INTERCHANGE

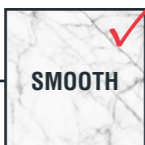

SMOOTH ✓



BUSH-HAMMERED ✓



FLAMED ✓

suitable for all finishes

Which is the best model?

None of them is better than the other - it all depends on your lifting needs. Learn more about our S1 series to find the best fit for you.



Kg max
600

Professional lifting equipment for frequent and prolonged use

Powered by high-capacity, rechargeable batteries

Smart Vacuum Control Unit

Weights only 20kg



Kg max
1000

Great lifting equipment for short-term or low intensity works

Powered either by compressed air or by hand pump with double action

High-Safety devices

Weights only 18kg



NATURAL ✓

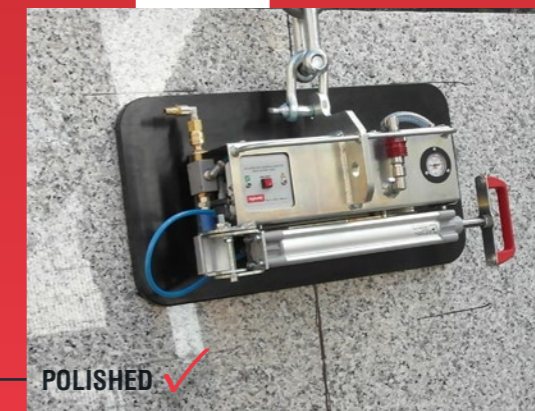

POLISHED ✓

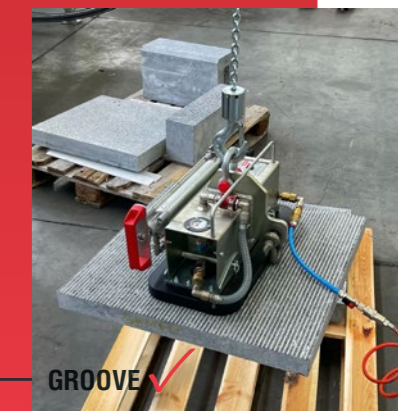

GROOVE ✓

S1-MP



The S1-MP vacuum lifter has a dual operating system: the vacuum can be created either by compressed air or by manually pushing the double action pump. The latter option allows its use in full autonomy, without the need of constant connection to power supply.

Thanks to the interchangeable pads, this model can have lifting capacity up to 1000kg.

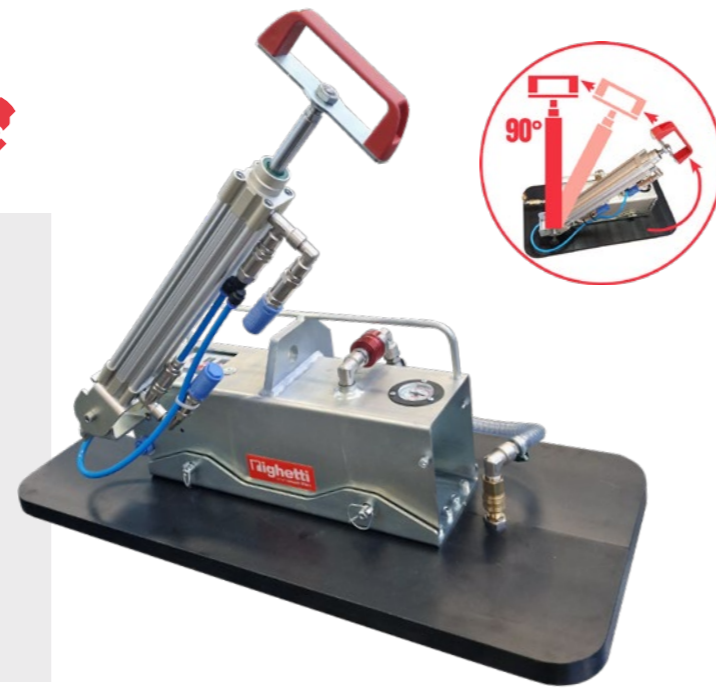

S1-MP series

max 1000 Kg

Capacity Kg	Pads no.	Tare kg	Suction pads size (AxB) mm		Model
			Equipment	To be added	
Max 600 kg	1	18	-	Pad of the category A	S1-MP-600.2
Max 800 kg	1	26	830x420 (cat. B)	Pad of the category A	S1-MP-800
Max 1000 kg	1	33	900x480 (cat. C)	Pad of the category A	S1-MP-1000

Choose your preferred suction pad(s)

Category	Capacity Kg		Pad dimensions mm		Product code	Model			
	horizontal	vertical	X	Y		S1-MP-600	S1-MP-800	S1-MP-1000	S1-B
A	50	-	450	100	S1-450100	•	•	•	•
	100	-	250	250	S1-250250	•	•	•	•
		-	660	100	S1-660100	•	•	•	•
	200	100	760	150	S1-760150	•	•	•	•
	250	125	480	230	S1-480230	•	•	•	•
	300	150	760	200	S1-760200	•	•	•	•
	450	225	630	330	S1-630330	•	•	•	•
600	300	760	350	S1-760350	•	•	•	•	
B	800	400	830	420	S1-830420	-	included	•	-
C	1000	500	900	480	S1-900480	-	-	included	-

Technical drawings

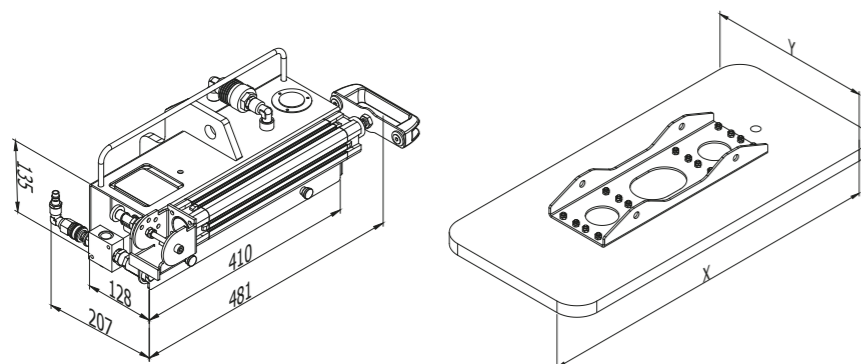

S1-B



S1-B is a battery powered vacuum lifter, whose battery can be easily recharged. The Vacuum Control Unit not only states the battery level but also monitors the vacuum in the circuit and warns the operator in case of potential dangers.

Thanks to its compact size, lightweight frame and interchangeable pads, it is perfect for all outdoor stone applications up to 600kg.

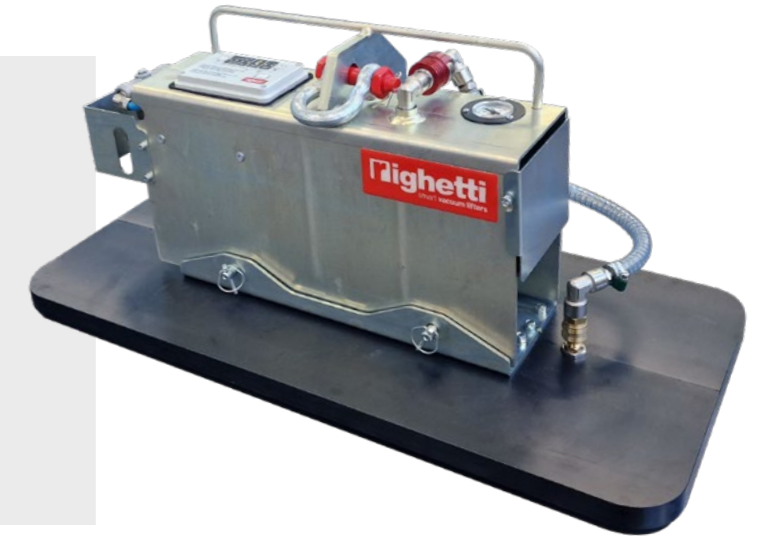

S1-B series

Max 600 Kg

Capacity Kg	Pads no.	Tare kg	Suction pads size (AxB) mm		Model
			Equipment	To be added	
Max 600 kg	1	26	-	Pad of the category A	S1-B



• Available | - Not available | **Included** standard feature
To order please indicate the model of the vacuum lifter and the desired suction pad

Technical drawings

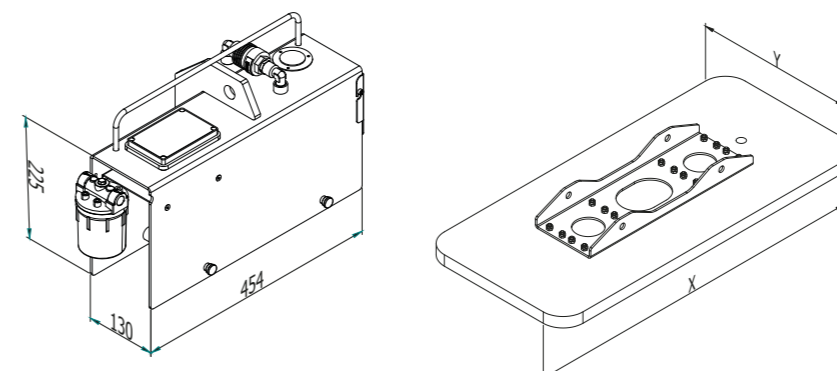

Adaptable to any environment

New lifting needs? New suction pad!

The peculiarity of S1 series is the **interchangeability** of its suction pads to **adapt the dimensions and lifting capacity** to the load. If you need to handle some new loads with different size and weight, you can always count on our interchangeable suction pads.

Simply check the chart in the previous pages and **choose the best suction pad for your needs!**

CHANGE PAD IN 3 STEPS:

- 1 Remove locking pins and detach the vacuum hose
2. Put machinery body on another suction pad
3. Secure pins and attach the vacuum hose back

50kg capacity
450 x 100mm

200kg capacity
760 x 150mm

300kg capacity
760 x 200mm

800kg capacity
830 x 420mm

Carrying handles for a safe stone installation

The dual grip handlebar is an useful optional that can be easily mounted on all S1 models. It allows the **manual lifting of the load by two people** for all those cases where the working site is not reachable with traditional lifting means.

Thanks to its maximum lifting capacity of **100 kg**, the dual grip handlebar makes stone installation easier, while **protecting the workers from potenzial health hazards** such as pinched fingers, fatigue and joint pains.



✓ Precise laying

✓ Safe grip from above

✓ Max 100kg

Hassle-free lifting long and narrow slabs

When **lifting and installing long, narrow paving slabs**, the beam with suction pads is a useful ally. This accessory gets attached to the main body of the S1 series to provide stable and uniform support to the entire load thanks to its **length of 155cm**. The user can choose to use two or three suction pads.

The design of this optional aims to prevent the risk of damaging the material during its lifting, as it **ensures a balanced distribution of the load** and contributes to its precise and effortless laying.



ITS

Righetti srl

Via della Meccanica, 20
37139 Verona ITALY

Tel. +39 045 7157621
info@righettisollevamenti.it

Righetti
smart vacuum lifters



righettivacuumlifters.com