

# Kitchen top vacuum lifter

Series

## P3A-K



Kg max  
**330**

**AIR** Power supply  
Compressed Air



The P3A-K is a series of vacuum lifters which are **specific for kitchen tops** and have a maximum lifting capacity of 330 kg. This lifter is powered by compressed air. The **pneumatic tilting system** allows an assisted movement of the load from vertical to horizontal and vice versa, controlled by a joystick. Equipped with an on-off sliding valve against the involuntary release of the load. The vacuum gauge with coloured scale installed on the vacuum circuit allows constant control of the vacuum level reached in the circuit itself.

Equipped with an **audio-visual alarm** control unit that warns the operator of possible dangerous situations. Present a **filtering system for dust and condensation**. The vacuum tank accelerates the gripping and together with the non-return valve, ensures that the load is not immediately released if there is a sudden power failure.



### Technical specification

<b>Application</b>	Not porous stones
<b>Lifting capacity</b>	270 kg on model P3A270K 330 kg on model P3A330K
<b>Suction pads</b>	Nr. 3 rectangular suction pads mm 480x180 on model P3A270K mm 580x180 on model P3A330K
<b>Load movement</b>	0 – 90° powered tilt by pneumatic cylinder
<b>Operating system</b>	Compressed air
<b>Vacuum system</b>	Vacuum circuit, complete of vacuum reserve and non-return valve
<b>Control</b>	Manual valve on the lifter's frame Release of the load by dual action security command
<b>Standard features</b>	Lifting beam L. 2200 mm On-off double sliding valve with safety Audible and visual low vacuum warning devices Vacuum gauge with colored scale, vacuum filter, non-return valves
<b>Optional</b>	White gaskets Holder for hoist command Turnable pads 90°



Horizontal lifting



Vertical lifting



Pneumatic tilt 0-90°



3 suction pads



Max capacity 330 kg



Safety devices

## Kitchen top vacuum lifter

### Optional

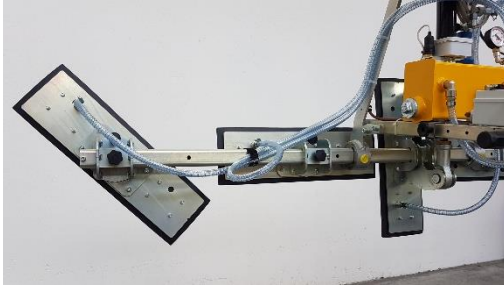

Support for quick rotation of the pads



White gaskets

### Technical drawing

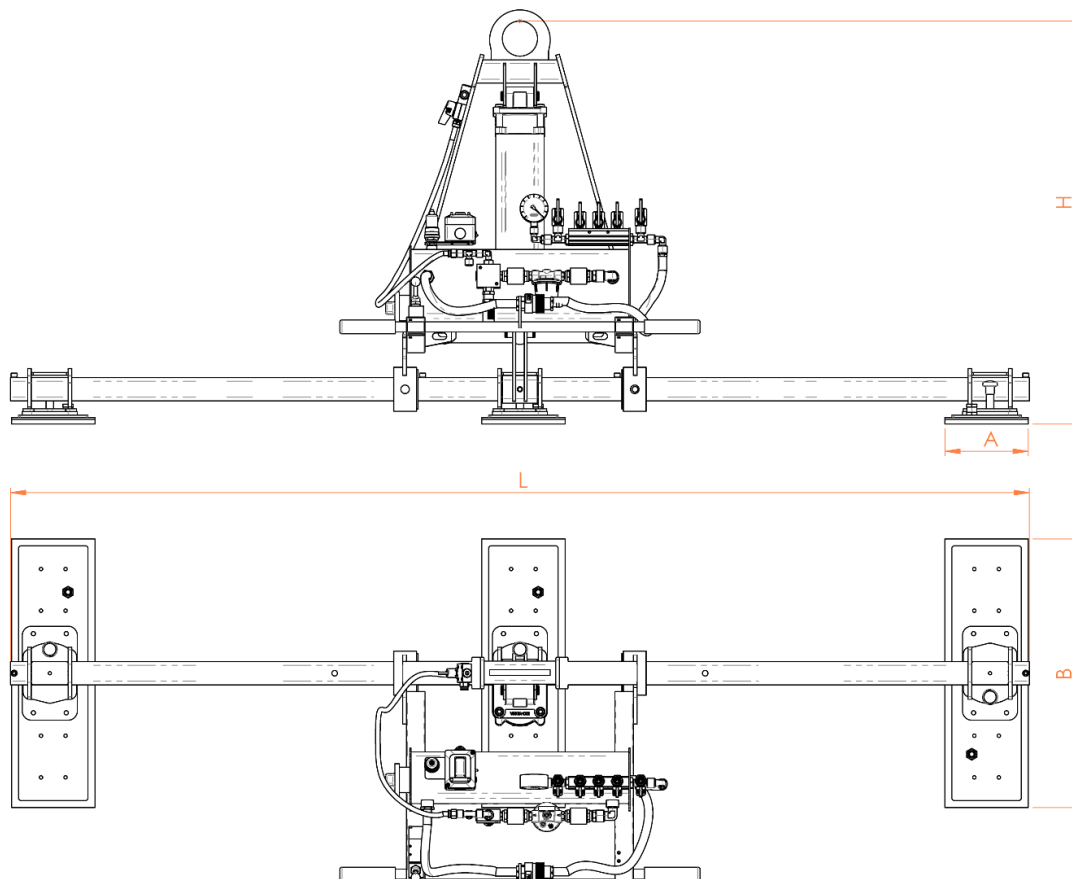

### Series -P3A-K

 **Kg max 330**

Product code	Lifting capacity kg	A mm	B mm	L mm	H mm
P3A270K	270	180	480	2200	870
P3A330K	330	180	580	2200	870